

ValsMatik Plus Kontrol Ünitesi

RollerMatic Plus Control Unit

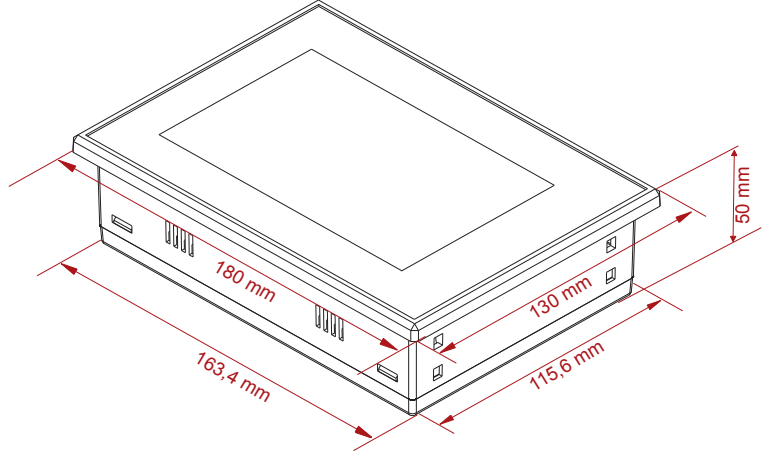

VALSMATİK PLUS KONTROL ÜNİTESİ

GENEL ÖZELLİKLERİ

Valsmatik Plus Kontrol Ünitesi; Vals makinelerinin manuel ve full otomatik kontrolünü sağlayan yüksek performanslı çift mikrodenetleyici tabanlı kontrol cihazıdır. Vals makinesinin; akım, devir ve fanus seviye kontrollerini sağlar.

Teknik Özellikler:

- 5" Monokrom grafik LCD ile kolay ve hızlı programlama,
 - Cihaz üzerinde start/stop, auto-man, centil ve led tuşları bulunur,
 - Loadcell amplifikatörü,
 - Buzzer ile sesli ikaz sistemi,
 - 1 adet analog çıkış kanalı 0-10V,
 - 2 adet analog giriş kanalı ile akım okuma,
 - 1 adet devir sayacı (danelik motoru),
 - 2 adet devir bekçisi (kayış kopma),
 - 11 adet programlanabilir dijital giriş,
 - 11 adet programlanabilir dijital çıkış.
- Besleme voltajı: 24V DC



ROLLERMATIC PLUS CONTROL UNIT

GENERAL FEATURES

Rollermatic Plus Control Unit; It is a high-performance dual microcontroller based controller that provides manual and fully automatic control of roller machines. Roller Machine; flow, speed (ROUND) and lantern level controls.

General Features:

- Easy and fast programming with 5" monochrome graphic LCD,
 - The device has start/stop, auto-man, centil and led buttons,
 - Loadcell amplifier,
 - Audible warning system with buzzer,
 - 1 pcs analog output channel 0-10V,
 - Current reading with 2 analog input channels,
 - 1 pcs speed counter (feeder motor),
 - 2 pcs speed guard (belt break),
 - 11 pcs programmable digital inputs,
 - 11 pcs programmable digital outputs.
- Supply voltage: 24V DC

PARTNERLERİMİZ / OUR PARTNERS



SERTİFİKALARIMIZ / CERTIFICATES



Where Techonology Meets the Hearth of Industry



Head Office & Fabric ;

Büyükkayacık OSB. 513 Nolu Sokak
No:9 Selçuklu / Konya

E-Mail ;

info@atara.com.tr

Telephone ;

+90 332 345 0206

